

FMH SERIES



"FMH Series" Gerotor Hydraulic Motors are having spool valve design Hydraulic Motors with Roller Stator suitable for Medium & Heavy Duty Applications

Applications:

- Construction Equipments
- Mining Equipments
- Concrete Pumps
- Mobile Crane Winches

	FMH 200	FMH 250	FMH 300	FMH 400	FMH 500
Displacement (cc/rev)	200	250	300	400	500
Speed (Max) (rpm)	350	280	235	175	140
Torque (Max) Kg.M	47	59	71	84	85
Flow (Max) (Lpm)	75	75	75	75	75
Pressure (Max) (Kg/cm <sup>2</sup> )	175	175	175	155	125
Output (Max) (HP)	16.0	16.0	14.0	12.5	11.0
Length 'L' (mm)	171	178	186	198	210
Weight (Kg)	8.5	9.0	9.5	10.0	11.0

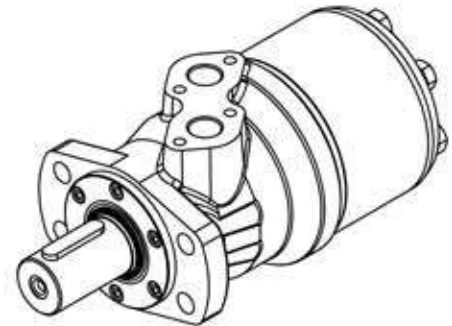
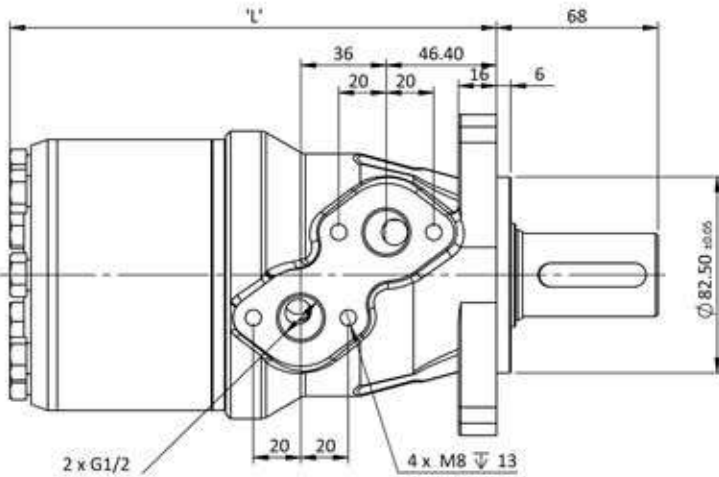
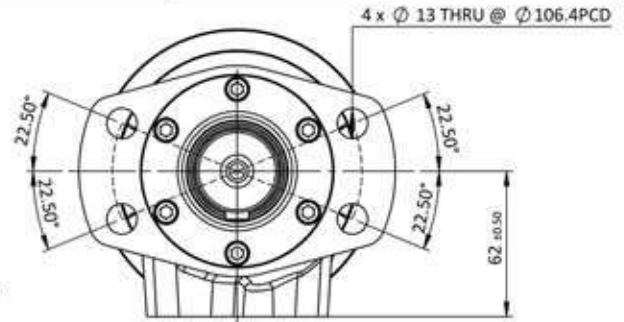
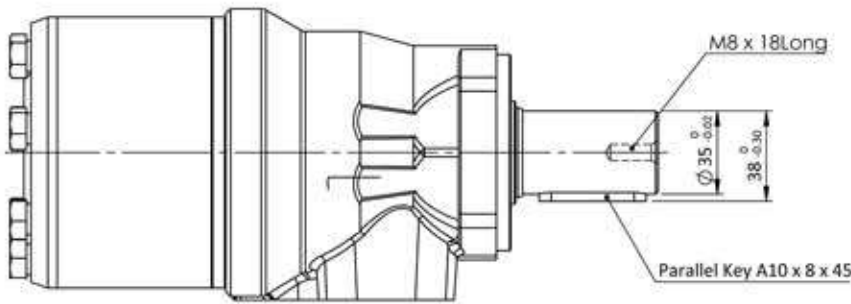

TORQUE vs PRESSURE

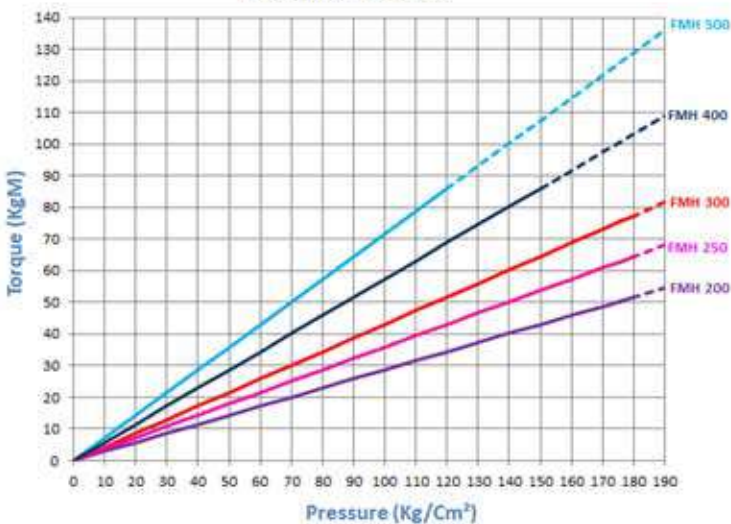

SPEED vs FLOW

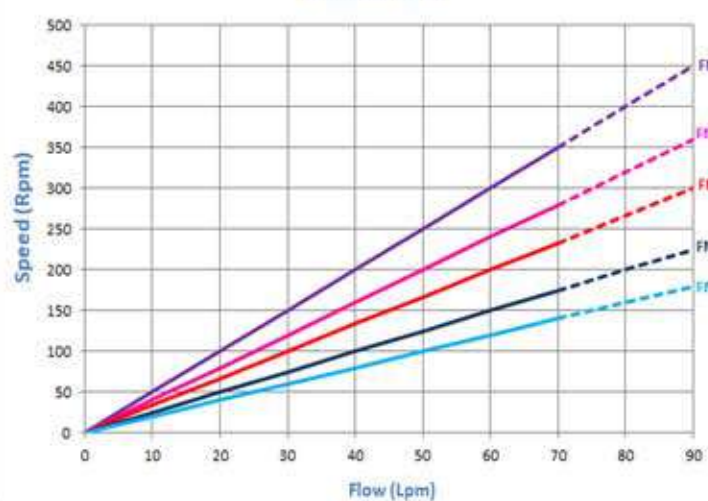

Dotted Lines Indicate Operation in this region is not recommended for continuous application